

TOSHIBA

**DISCONTINUATION NOTICE
TB62701ANG**

**THE FOLLOWING HAS BEEN
DISCONTINUED AS OF MAR 2009:**

TB62701ANG

**PLEASE SEE SUGGESTED
REPLACEMENT DRIVER:**

TB62747AFGEL

**CONTACT MARKTECH
ENGINEERING OR SALES
FOR APPLICATION ASSISTANCE**



TOSHIBA Bi-CMOS INTEGRATED CIRCUIT SILICON MONOLITHIC

TB62701ANG

16BIT SHIFT REGISTER, LATCH & CONSTANT CURRENT DRIVERS

The TB62701ANG is specifically designed for LED and LED-DISPLAY constant current drivers. This constant current output circuit is able to set up external resistor ($I_{OUT} = 5$ to 50mA). This IC is monolithic integrated circuit designed to be used together with Bi-CMOS process. The devices consist of 16bit Shift Register, Latch, AND-GATE and Constant Current Driver.

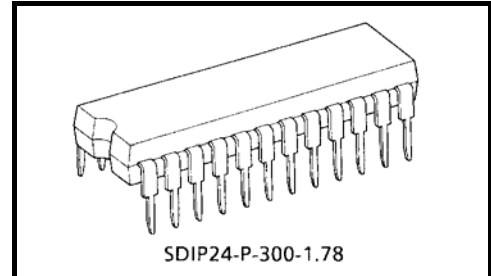

Weight: 1.22 g (typ.)

FEATURES

- OUTPUT CURRENT : Set-up at 50mA maximum with an external resistor.
- A LITTLE CHANGE OF OUTPUT CURRENT ($T_a = 25^\circ\text{C}$, $V_{DD} = 5.0\text{ V}$)

OUTPUT-GND VOLTAGE	A LITTLE CHANGE OF CHANNEL	I_{OUT} [mA]
$\geq 0.4\text{ V}$	$\pm 7\%$	5 ~ 50 mA
$\geq 0.7\text{ V}$		

- 5V CMOS Compatible Input
- PACKAGE : SDIP-24 (SDIP24-P-300)
- MAXIMUM CLOCK FREQUENCY : $f_{MAX} = 2.5\text{ MHz}$ (cascade operation, $T_a = 25^\circ\text{C}$)

PIN CONNECTION (TOP VIEW)

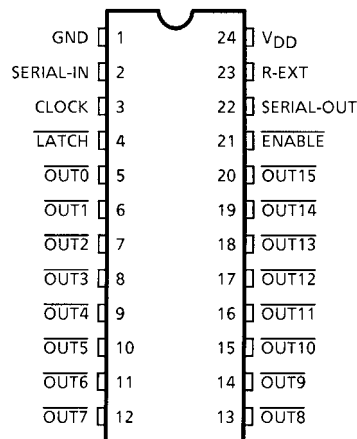

Web: www.marktechopto.com | Email: info@marktechopto.com

BLOCK DIAGRAM

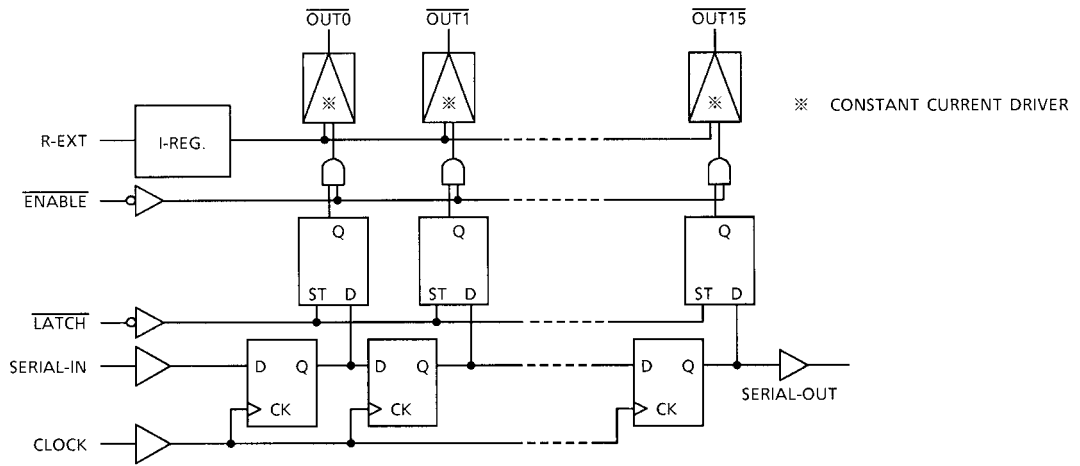

TIMING DIAGRAM

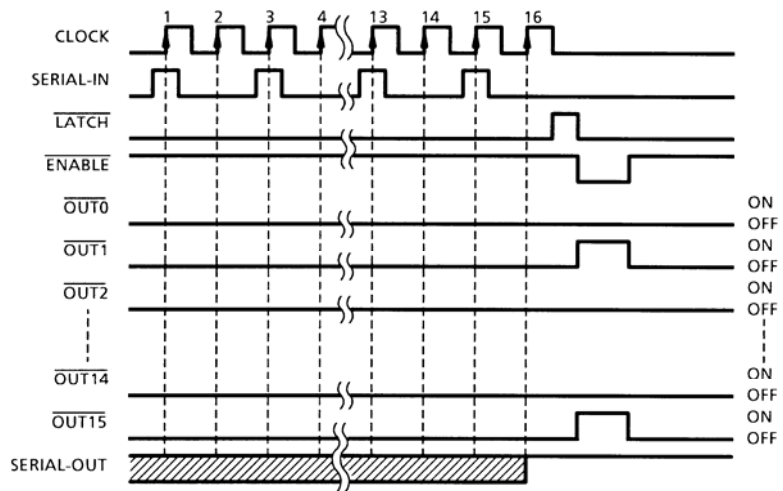

TERMINAL DESCRIPTION

PIN No.	PIN NAME	FUNCTION
1	GND	GND terminal for control logic driver
2	SERIAL-IN	Serial data input terminal for shift register
3	CLOCK	Clock input terminal for data shift to up-edge
4	$\overline{\text{LATCH}}$	"H" Level : data through, "L" Level : data hold
24	V_{DD}	Supply voltage terminal
5~12 13~20	$\overline{\text{OUT}}_n$	Output terminals
21	$\overline{\text{ENABLE}}$	"H" Level output off, "L" Level : latch data = "H" Level then output on, latch data = "L" Level then output off
22	SERIAL-OUT	Serial data output terminal for shift register
23	R-EXT	The register which connects between R-EXT and GND sets the constant output current.

TRUTH TABLE

INPUT				OUTPUT $\overline{\text{OUT}}_n$ (t = n)		
CLOCK	$\overline{\text{LATCH}}$	ENABLE	SERIAL-IN	$\overline{\text{OUT}}_0 \dots \overline{\text{OUT}}_7 \dots \overline{\text{OUT}}_{15}$	SERIAL-OUT	
	H	L	D_n	D_n	D_{n-7}	D_{n-15}
	L	L	D_n	No change		
	(Note)	H	D_n	OFF	OFF	OFF
	(Note)	(Note)	D_n	No change		

Note: $D_n \sim D_{n-15}$ = "H" then OUT_n is ON, "L" then OUT_n is OFF.

EQUIVALENT CIRCUIT OF INPUTS AND OUTPUTS

1. $\overline{\text{ENABLE}}$ terminal

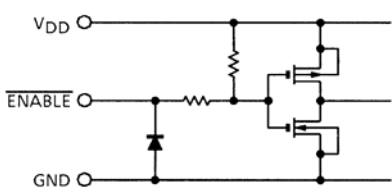

2. $\overline{\text{LATCH}}$ terminal

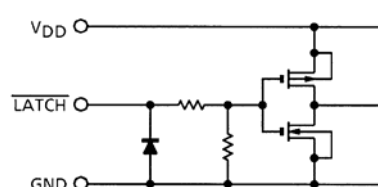

3. CLOCK, SERIAL-IN terminal

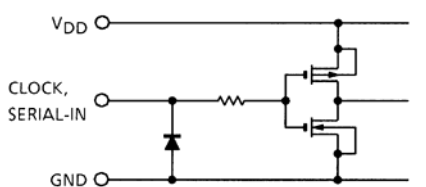

4. SERIAL-OUT terminal

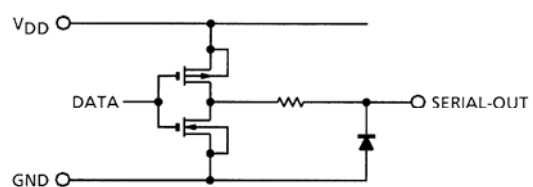

ABSOLUTE MAXIMUM RATINGS (Ta = 25°C)

CHARACTERISTIC	SYMBOL	RATING	UNIT
Supply Voltage	V _{DD}	0~7.0	V
Output Voltage	V _{CE}	-0.5~30	V
Output Current	I _{OUT}	50	mA
Input Voltage	V _{IN}	-0.4~V _{DD} + 0.4	V
GND Terminal Current	I _{GND}	800	mA
Clock Frequency	f _{CK}	2.5	MHz
Power Dissipation (Note)	P _D	1.78	W
Operating Temperature	T _{opr}	-40~85	°C
Storage Temperature	T _{stg}	-55~150	°C

Note: Ambient temperature delated above 25°C in the proportion of 14.2 mW / °C.

RECOMMENDED OPERATING CONDITION (Ta = -40~85°C unless otherwise noted)

CHARACTERISTIC		SYMBOL	TEST CONDITION	MIN	TYP.	MAX	UNIT
Supply Voltage		V _{DD}	—	4.5	5.0	5.5	V
Output Voltage		V _{OUT}	—	—	—	30.0	V
Output Current	$\overline{\text{OUTn}}$	I _{OUT}	DC 1 circuit	—	—	45	mA
	S-OUT	I _{OH}	—	—	—	-1.0	
		I _{OL}	—	—	—	1.0	
Input Voltage		V _{IN}	—	0	—	V _{DD}	V
Data Set Up Time		t _{setup} (D)	—	100	—	—	ns
Data Hold Time		t _{hold} (D)	—	20	—	—	ns
Data Set Up Time		t _{setup} (L)	—	300	—	—	ns
Data Hold Time		t _{hold} (L)	—	100	—	—	ns
Clock Pulse Width		t _w CLK	—	100	—	—	ns
		t _w $\overline{\text{CLK}}$	—	100	—	—	ns
Latch Pulse Width		t _w LAT	—	300	—	—	ns
		t _w $\overline{\text{LAT}}$	—	300	—	—	ns
Clock Frequency		f _{CK}	Cascade operation	—	—	2.0	MHz
Power Dissipation		P _D	Ta = 85°C	—	—	0.72	W

ELECTRICAL CHARACTERISTICS ($V_{DD} = 5.0\text{ V}$, $T_a = 25^\circ\text{C}$ unless otherwise noted)

CHARACTERISTIC		SYMBOL	TEST CIR-CUIT	TEST CONDITION	MIN	TYP.	MAX	UNIT
Input Leakage Current	"H" level	V_{IH}	—	—	70% V_{DD}	—	V_{DD}	V
	"L" level	V_{IL}	—	—	GND	—	30% V_{DD}	
Output Leakage Current		I_{OH}	—	$V_{OH} = 30\text{V}$	—	—	10	μA
Output Voltage	S-OUT	V_{OL}	—	$I_{OL} = +1.0\text{ mA}$	—	—	0.4	V
		V_{OH}	—	$I_{OH} = -1.0\text{ mA}$	4.6	—	—	
Output Current 1		I_{OL1}	—	$V_{CE} = 0.7\text{ V}$	35.2	41.5	47.7	mA
		I_{OL2}	—	$V_{CE} = 0.4\text{ V}$				
	Delta I_{OUT}	ΔI_{OL1}	—	$R_{EXT} = 560\ \Omega$ $I_{OUT} = 40\text{ mA}$, $V_{CE} = 0.4\text{ V}$		—	± 3.0	± 7.0
Supply Voltage Regulation		% / V_{DD}	—	$R_{EXT} = 560\ \Omega$	—	18	—	% / V
Reference Voltage		V_{ref}	—	$R_{EXT} = 560\ \Omega$, $T_a = -40\sim 85^\circ\text{C}$	—	1.26	—	V
Pull Up / Down Resistor		R_{IN}	—	—	100	200	400	$\text{k}\Omega$
Supply Current	"OFF"	$I_{DD}(\text{off})1$	—	$R_{EXT} = \text{OPEN}$, $\text{OUT}_n = \text{Off}$	—	0.4	0.6	mA
		$I_{DD}(\text{off})2$	—	$R_{EXT} = 560\ \Omega$, $\text{OUT}_n = \text{Off}$	—	6.5	10.0	
	"ON"	$I_{DD}(\text{on})$	—	$R_{EXT} = 560\ \Omega$, All output on	—	13.5	20.0	

SWITCHING CHARACTERISTICS (Ta = 25°C unless otherwise noted)

CHARACTERISTIC		SYMBOL	TEST CONDITION	MIN	TYP.	MAX	UNIT				
Propagation Delay Time ("L" to "H")	CLK-S-OUT	t _{pLH}	V _{DD} = 5.0 V V _{CE} = 1.0 V V _{IH} = V _{DD} V _{IL} = GNK f _{CK} = 2 MHz R _{EXT} = 560 Ω I _{OUT} = 30 mA	—	95	500	ns				
	CLK- $\overline{\text{OUTn}}$			—	130	500					
	$\overline{\text{LATCH}}-\overline{\text{OUTn}}$			—	130	500					
	$\overline{\text{EN}}-\overline{\text{OUTn}}$			—	130	500					
Propagation Delay Time ("H" to "L")	CLK-S-OUT	t _{pHL}		V _{DD} = 5.0 V V _{CE} = 1.0 V V _{IH} = V _{DD} V _{IL} = GNK f _{CK} = 2 MHz R _{EXT} = 560 Ω I _{OUT} = 30 mA	—	95	720	ns			
	CLK- $\overline{\text{OUTn}}$				—	130	500				
	$\overline{\text{LATCH}}-\overline{\text{OUTn}}$				—	130	500				
	$\overline{\text{EN}}-\overline{\text{OUTn}}$				—	130	500				
Maximum Clock Frequency		f _{MAX} (Note 1)			V _{DD} = 5.0 V V _{CE} = 1.0 V V _{IH} = V _{DD} V _{IL} = GNK f _{CK} = 2 MHz R _{EXT} = 560 Ω I _{OUT} = 30 mA	2.0	—	2.5	MHz		
Minimum Pulse Width	CLK	t _w CLK				—	45	80	ns		
	$\overline{\text{LATCH}}$	t _w $\overline{\text{LAT}}$				—	10	50			
Data Set Up Time		t _{setup} (D)				V _{DD} = 5.0 V V _{CE} = 1.0 V V _{IH} = V _{DD} V _{IL} = GNK f _{CK} = 2 MHz R _{EXT} = 560 Ω I _{OUT} = 30 mA	—	17	50	ns	
Data Hold Time		t _{hold} (D)	—				-7	10			
Latch Set Up Time	LH	t _{LAT} setup	V _{DD} = 5.0 V V _{CE} = 1.0 V V _{IH} = V _{DD} V _{IL} = GNK f _{CK} = 2 MHz R _{EXT} = 560 Ω I _{OUT} = 30 mA				—	70	200	ns	
	HL						—	70	200		
Latch Hold Time	LH	t _{LAT} hold					V _{DD} = 5.0 V V _{CE} = 1.0 V V _{IH} = V _{DD} V _{IL} = GNK f _{CK} = 2 MHz R _{EXT} = 560 Ω I _{OUT} = 30 mA	—	-70	50	ns
	HL			—				-70	50		
Maximum Clock Rise Time		t _r		V _{DD} = 5.0 V V _{CE} = 1.0 V V _{IH} = V _{DD} V _{IL} = GNK f _{CK} = 2 MHz R _{EXT} = 560 Ω I _{OUT} = 30 mA				—	—	10	μs
Maximum Clock Fall Time		t _f						—	—	10	
Maximum Output Rise Time		t _{or}						V _{DD} = 5.0 V V _{CE} = 1.0 V V _{IH} = V _{DD} V _{IL} = GNK f _{CK} = 2 MHz R _{EXT} = 560 Ω I _{OUT} = 30 mA	—	35	80
Maximum Output Fall Time		t _{of}			—				40	80	

Note 1: Cascade operation

DC CHARACTERISTIC TEST CIRCUIT

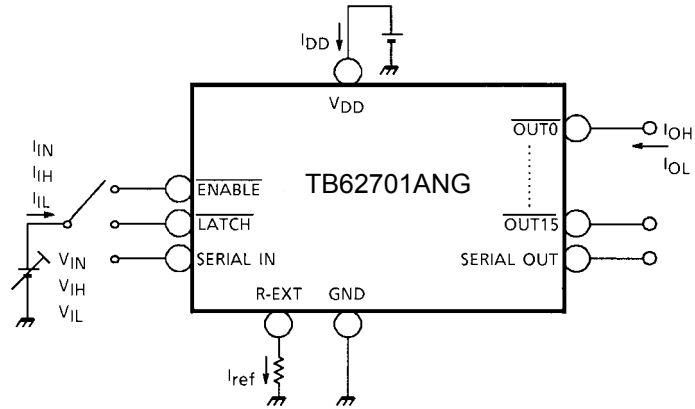

AC CHARACTERISTIC TEST CIRCUIT

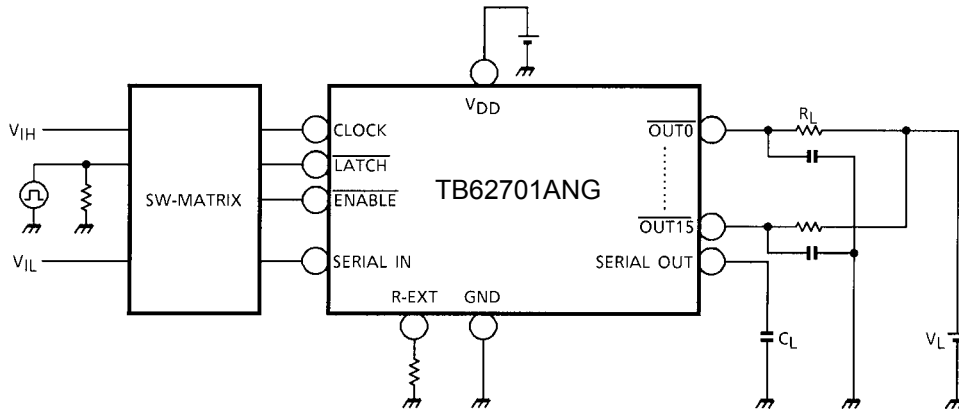

TIMING WAVE FORM

1. CLOCK-SERIAL OUT, OUTn

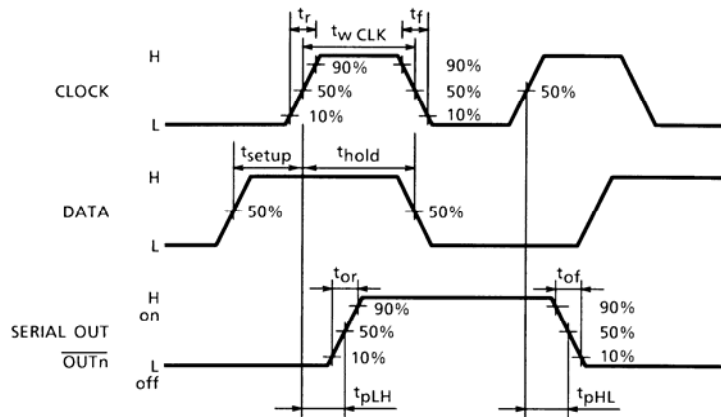

2. CLOCK-LATCH

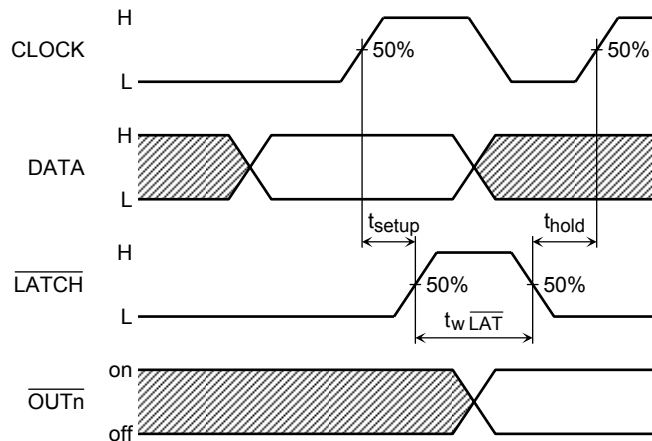

3. ENABLE

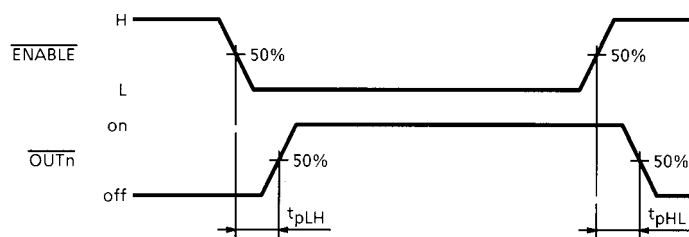

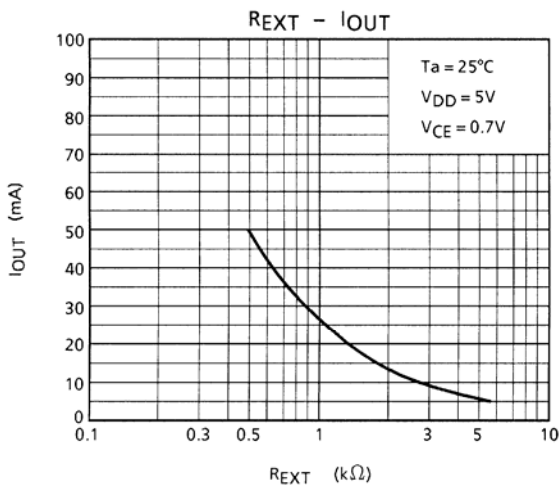
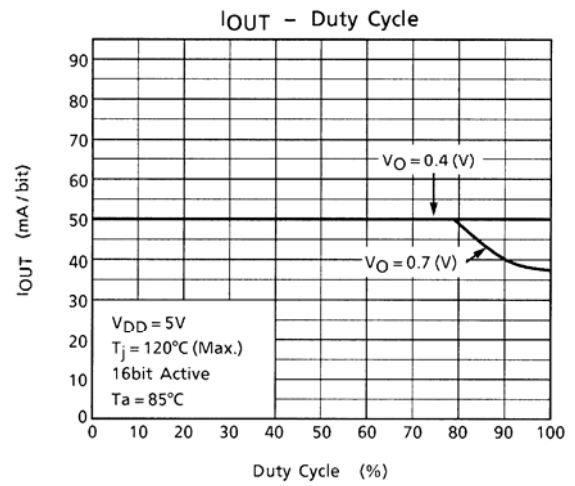
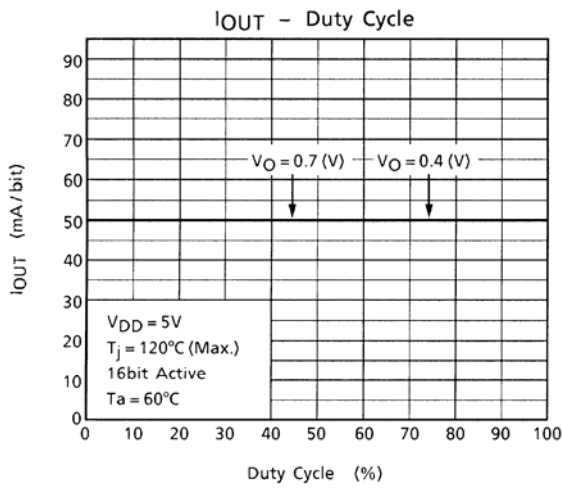
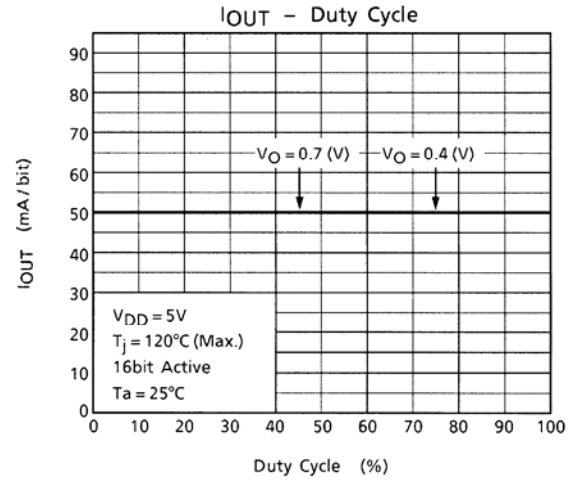
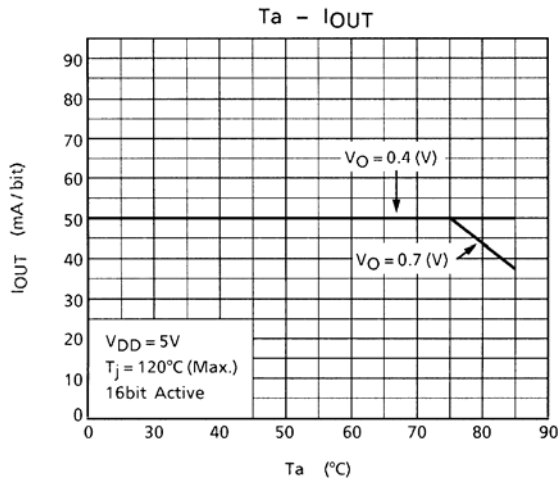

$$I_{OUT} \text{ (mA)} = \{1.26 \text{ (V)}/R_{EXT} \text{ (}\Omega)\} \times 18.4$$

APPLICATION CIRCUIT

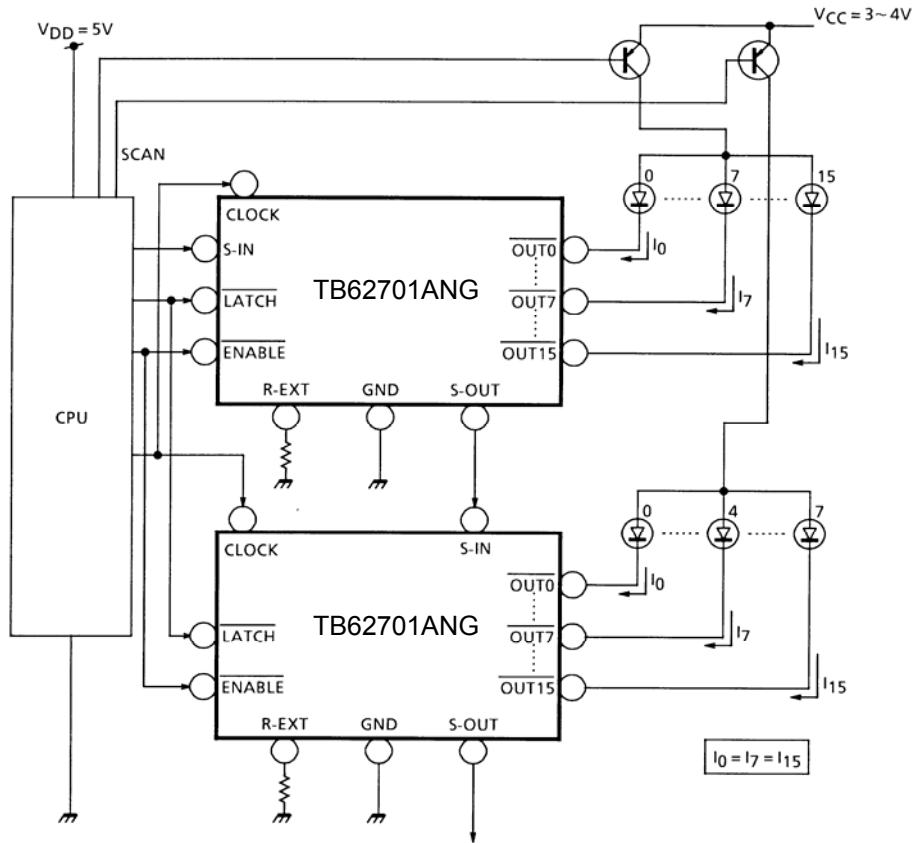

PRECAUTIONS for USING

Utmost care is necessary in the design of the output line, VCC (VDD) and GND line since IC may be destroyed due to short-circuit between outputs, air contamination fault, or fault by improper grounding.

Package Dimensions

SDIP24-P-300-1.78

Unit : mm

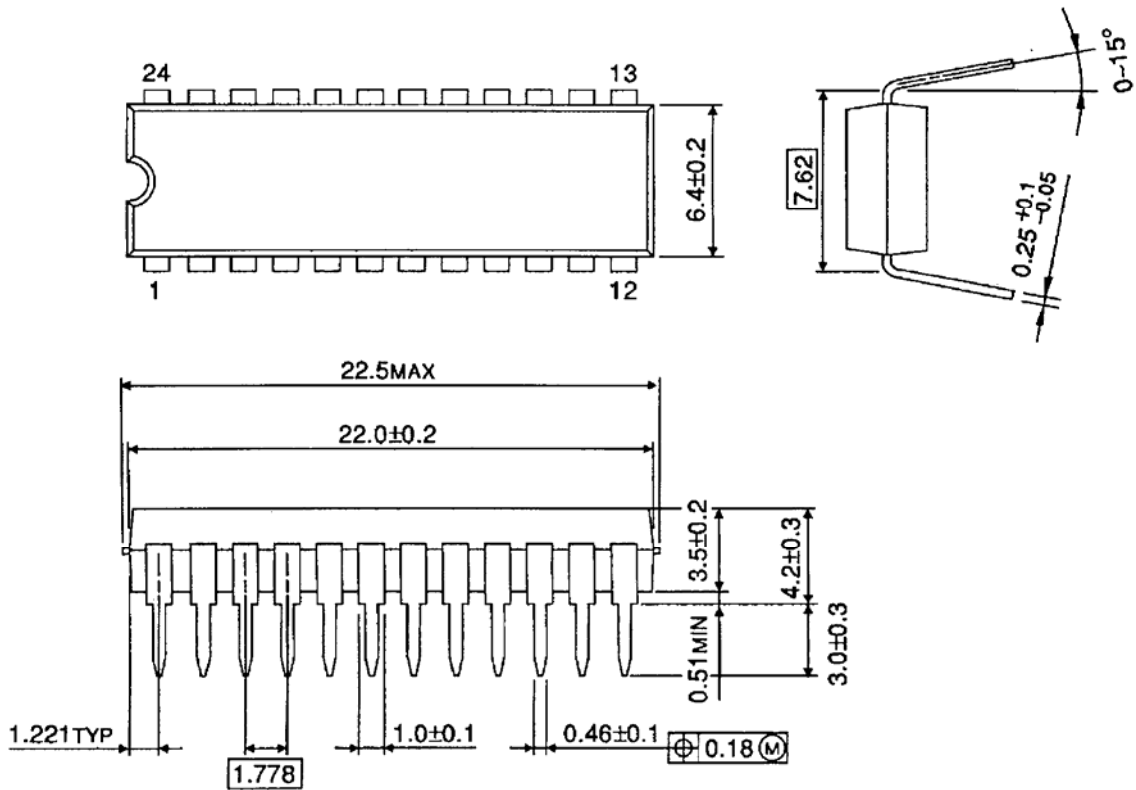

Weight: 1.22 g (typ.)

Notes on Contents**1. Block Diagrams**

Some of the functional blocks, circuits, or constants in the block diagram may be omitted or simplified for explanatory purposes.

2. Equivalent Circuits

The equivalent circuit diagrams may be simplified or some parts of them may be omitted for explanatory purposes.

3. Timing Charts

Timing charts may be simplified for explanatory purposes.

4. Application Circuits

The application circuits shown in this document are provided for reference purposes only.

Thorough evaluation is required, especially at the mass production design stage.

Toshiba does not grant any license to any industrial property rights by providing these examples of application circuits.

5. Test Circuits

Components in the test circuits are used only to obtain and confirm the device characteristics. These components and circuits are not guaranteed to prevent malfunction or failure from occurring in the application equipment.

IC Usage Considerations

Notes on Handling of ICs

- (1) The absolute maximum ratings of a semiconductor device are a set of ratings that must not be exceeded, even for a moment. Do not exceed any of these ratings.
Exceeding the rating(s) may cause the device breakdown, damage or deterioration, and may result injury by explosion or combustion.
- (2) Use an appropriate power supply fuse to ensure that a large current does not continuously flow in case of over current and/or IC failure. The IC will fully break down when used under conditions that exceed its absolute maximum ratings, when the wiring is routed improperly or when an abnormal pulse noise occurs from the wiring or load, causing a large current to continuously flow and the breakdown can lead smoke or ignition. To minimize the effects of the flow of a large current in case of breakdown, appropriate settings, such as fuse capacity, fusing time and insertion circuit location, are required.
- (3) If your design includes an inductive load such as a motor coil, incorporate a protection circuit into the design to prevent device malfunction or breakdown caused by the current resulting from the inrush current at power ON or the negative current resulting from the back electromotive force at power OFF. IC breakdown may cause injury, smoke or ignition.
Use a stable power supply with ICs with built-in protection functions. If the power supply is unstable, the protection function may not operate, causing IC breakdown. IC breakdown may cause injury, smoke or ignition.
- (4) Do not insert devices in the wrong orientation or incorrectly.
Make sure that the positive and negative terminals of power supplies are connected properly. Otherwise, the current or power consumption may exceed the absolute maximum rating, and exceeding the rating(s) may cause the device breakdown, damage or deterioration, and may result injury by explosion or combustion.
In addition, do not use any device that is applied the current with inserting in the wrong orientation or incorrectly even just one time.
- (5) Carefully select external components (such as inputs and negative feedback capacitors) and load components (such as speakers), for example, power amp and regulator.
If there is a large amount of leakage current such as input or negative feedback condenser, the IC output DC voltage will increase. If this output voltage is connected to a speaker with low input withstand voltage, overcurrent or IC failure can cause smoke or ignition. (The over current can cause smoke or ignition from the IC itself.) In particular, please pay attention when using a Bridge Tied Load (BTL) connection type IC that inputs output DC voltage to a speaker directly.

Points to Remember on Handling of ICs

- (1) Heat Radiation Design
In using an IC with large current flow such as power amp, regulator or driver, please design the device so that heat is appropriately radiated, not to exceed the specified junction temperature (T_j) at any time and condition. These ICs generate heat even during normal use. An inadequate IC heat radiation design can lead to decrease in IC life, deterioration of IC characteristics or IC breakdown. In addition, please design the device taking into consideration the effect of IC heat radiation with peripheral components.
- (2) Back-EMF
When a motor rotates in the reverse direction, stops or slows down abruptly, a current flow back to the motor's power supply due to the effect of back-EMF. If the current sink capability of the power supply is small, the device's motor power supply and output pins might be exposed to conditions beyond maximum ratings. To avoid this problem, take the effect of back-EMF into consideration in system design.

RESTRICTIONS ON PRODUCT USE

060116EBA

- The information contained herein is subject to change without notice. 021023_D
- TOSHIBA is continually working to improve the quality and reliability of its products. Nevertheless, semiconductor devices in general can malfunction or fail due to their inherent electrical sensitivity and vulnerability to physical stress. It is the responsibility of the buyer, when utilizing TOSHIBA products, to comply with the standards of safety in making a safe design for the entire system, and to avoid situations in which a malfunction or failure of such TOSHIBA products could cause loss of human life, bodily injury or damage to property.
In developing your designs, please ensure that TOSHIBA products are used within specified operating ranges as set forth in the most recent TOSHIBA products specifications. Also, please keep in mind the precautions and conditions set forth in the "Handling Guide for Semiconductor Devices," or "TOSHIBA Semiconductor Reliability Handbook" etc. 021023_A
- The TOSHIBA products listed in this document are intended for usage in general electronics applications (computer, personal equipment, office equipment, measuring equipment, industrial robotics, domestic appliances, etc.). These TOSHIBA products are neither intended nor warranted for usage in equipment that requires extraordinarily high quality and/or reliability or a malfunction or failure of which may cause loss of human life or bodily injury ("Unintended Usage"). Unintended Usage include atomic energy control instruments, airplane or spaceship instruments, transportation instruments, traffic signal instruments, combustion control instruments, medical instruments, all types of safety devices, etc. Unintended Usage of TOSHIBA products listed in this document shall be made at the customer's own risk. 021023_B
- The products described in this document shall not be used or embedded to any downstream products of which manufacture, use and/or sale are prohibited under any applicable laws and regulations. 060106_Q
- The information contained herein is presented only as a guide for the applications of our products. No responsibility is assumed by TOSHIBA for any infringements of patents or other rights of the third parties which may result from its use. No license is granted by implication or otherwise under any patent or patent rights of TOSHIBA or others. 021023_C
- The products described in this document are subject to the foreign exchange and foreign trade laws. 021023_E